

Automotive Structural Design- 3D Modelling Preparation for FEA Analysis Of 40ft Combine Harvester Trailer

Hamilton
By
Design

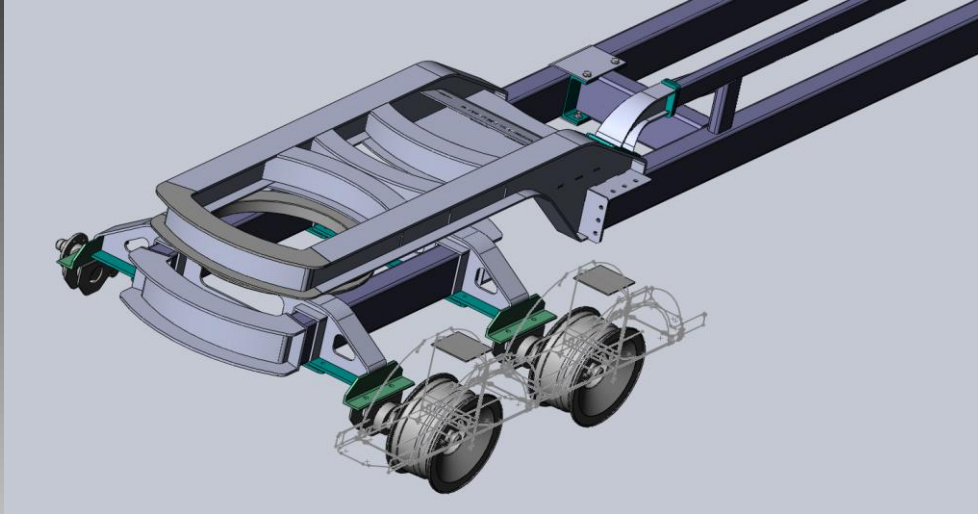

Challenges:

- Offer an attractive combine harvester carrier
- Offer a transport solution along with protection of expensive assets
- Meet RTA and government transportation regulations
- Design & Manufacture inside Australia with view to export.

